

Application Note



The Protection of USB 2.0 Applications

USB Port Protection

The USB-Interface might be the most distributed PC interface in the world. The usage in industry-applications is more and more common. Let's have a closer look to the special environmental conditions of industry applications.

That there are real concerns regarding the robustness against EMI and ESD is written in Intel's "High Speed USB Platform Design Guidelines". Intel recommends the usage of a common mode choke for EMI suppressions and another component for protection against ESD pulses.

Würth Elektronik offers all these types of products.

- The WE-CNSW common mode choke was developed for EMI suppression on high speed signal lines
- For ESD suppression the TVS diode arrays WE-TVS with very low capacitances (<2pF) or the ESD Suppressors WE-VE (capacitances down to 0.05pF) are your preferred choice.

But for outstanding EMI behaviour it is absolutely necessary to protect the power supply (V_{bus}) as well. A lot of design engineers forget this important point and wonder themselves when their product don't pass all the tests in EMI lab.

Two typical schematics for optimized protection of one or two USB ports are shown below:

With one TVS diode array WE-TVS you can fully protect two USB lines. All four signal lines as well as the common power supply are well protected. For further optimization, i.e. to filter incoming common mode noise as well as differential mode noise from USB line, a LC filter is built with the common mode choke WE-CNSW and the capacitors.

For power supply lines very good noise suppressions can be reached with a chip bead ferrite, like the Würth Elektronik WE-CBF series.

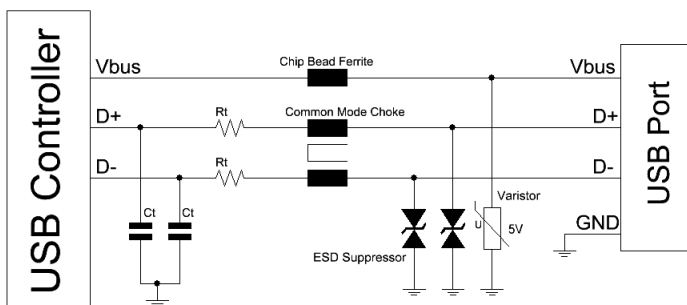
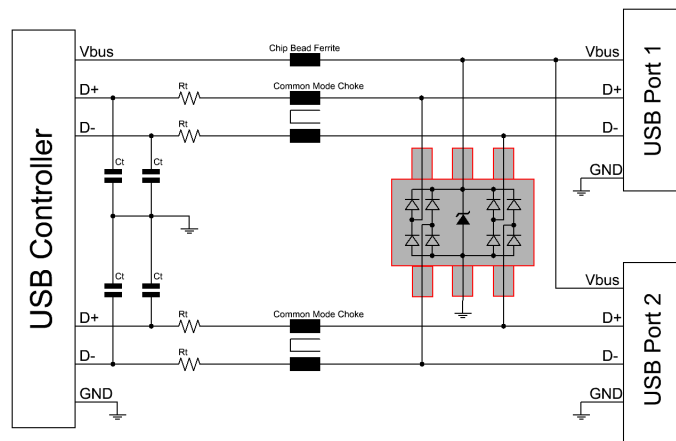

Single line protection components like ESD suppressors series WE-VE also have to be connected from signal line to GND. For power line protection it is not necessary to use a low cap ESD suppressor, you might prefer a standard SMD varistor which can withstand higher surges and higher transient energies.

Application Note

The Protection of USB 2.0 Applications



About TVS Diodes

Würth Elektronik launched the TVS diodes array series called WE-TVS. These TVS diodes arrays include three main functions:

- protection against ESD pulses according to EN 61000-4-2
- protection against surge pulses according to EN 61000-4-5
- protection against EFT pulses according to EN 61000-4-4

WE-TVS series are high performance designed TVS diode arrays which include surge rated diodes. They are the best choice to protect high speed data lines like USB 2.0, DVI or LAN from over-voltages. The WE-TVS series exceeds the requirements outlined in EN 61000-4-2. Due to their ultra low capacitance (<2.0 pF) they are nearly invisible on the signal lines.

About ESD Suppressors

The ESD suppressors are special raised varistors with a low and defined intrinsic capacitance. Würth Elektronik has three different series:

- WE-VE standard series: Capacitances of 1pF to 120pF and voltages from 5V to 24V
- WE-VE "ULC" series: Capacitance of 0.2pF, suitable for signal lines up to 12V
- WE-VE femtoF series: Capacitance of 0.05pF and rated voltages of 6V, 14V and 26V

For the first two series are also four-fold array packages available.

Why ESD Protection?

Since the first electronic developments, all the parts are subjected to electrostatic discharge. ESD events have peak voltages up to 30kV and therewith they are very dangerous for all kind of integrated circuits. However, some state-of-the-art ICs are protected against ESD pulses but real world conditions show daily that an additional protection device is indispensable. On the one hand to have the whole board ESD free and on the other hand to develop more reliable products to satisfy the needs of your customers.

Why EMI Suppression?

With the increase in electronic/electrical products and the need to have wireless connectivity in today's global markets, there is an increased requirement to ensure that your product is immune to the impacts caused by both the intentional and un-intentional RF environment. Only if you consider now which EMI phenomena impacts on the product, will you be able to design in the appropriate protection and reduce time to market.

In addition, the product must not generate excessive levels of EMI and this is typically assessed by an EMC Test Laboratory, and should the product fail then costs to implement remedial work will increase aggressively.

Application Note

The Protection of USB 2.0 Applications



Different Protection Devices for Different Requirements

There are four different TVS diode arrays and five different ESD Suppressors available:

Order Code	Package	Pin Conf.	I/O / VDD Lines	V _{RWM}	C _{IN}	I _{PP}	V _{ESD}	V _{Cl ESD}	VDD can float
824 011	SOT23-5L	1	2 / 1	5 V	2.0 pF	12 A	20 kV	13 V	No
824 015	SOT23-6L	2	4 / 1	5 V	2.0 pF	12 A	20 kV	13 V	No
824 001	SOT23-6L	2	4 / 1	5 V	1.0 pF	5 A	15 kV	14 V	No
824 014	SOT23-6L	3	4 / 1	5 V	0.5 pF	4 A	16 kV	12 V	Yes
823 07 050 029	0402	4	1	5 V	0.2 pF	-	8 kV	17 V	-
823 06 050 029	0603	4	1	5 V	0.2 pF	-	8 kV	30 V	-
823 81 120 029	0612	5	4	12V	0.2 pF	-	8 kV	30 V	-
823 17 06	0402	4	1	6 V	0.05 pF	-	8 kV	40 V	-
823 16 06	0603	4	1	6 V	0.05 pF	-	8 kV	40 V	-

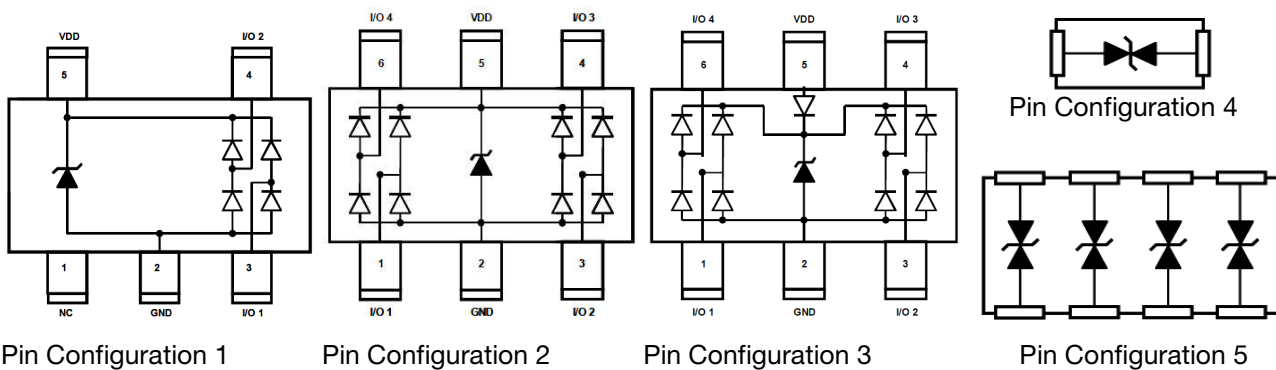

How to find the Suitable Part?

- You have supply voltage to connect for rail-to-rail clamping
→ take TVS diode
- You don't have supply voltage or do prefer ceramic components
→ take TVS diode where VDD pin can float or take WE-VE ESD suppressor
- Which maximum capacitance can you add to your data lines to pass the eye pattern test?
→ For USB 2.0 line capacitances up to 5pF shouldn't cause any trouble
- What's the maximum expected ESD voltage that can occur?
- Do you want to protect one or two USB lines? However, connecting one USB data line with two I/O ports of TVS diode lets you get a better performance → select array type

Answer all these questions and you will find the most suitable part for you.

We recommend for one USB 2.0 port 824 011 and for two USB 2.0 ports 824 015.

Designers preferring single line components may choose p/n 823 07 050 029 or 823 06 050 029.

Application Note



The Protection of USB 2.0 Applications

Eye Pattern Test

After making a choice of protection element you have to ensure that your whole interface design meets the requirements of USB specification. Therefore you can use our protection devices with a small capacitance which is nearly invisible on the signal lines.

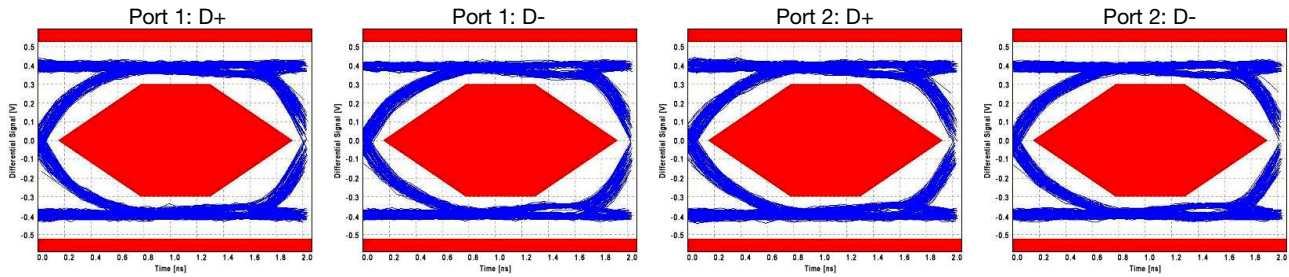

Eye pattern test without any protection component placed on two USB 2.0 differential signal lines

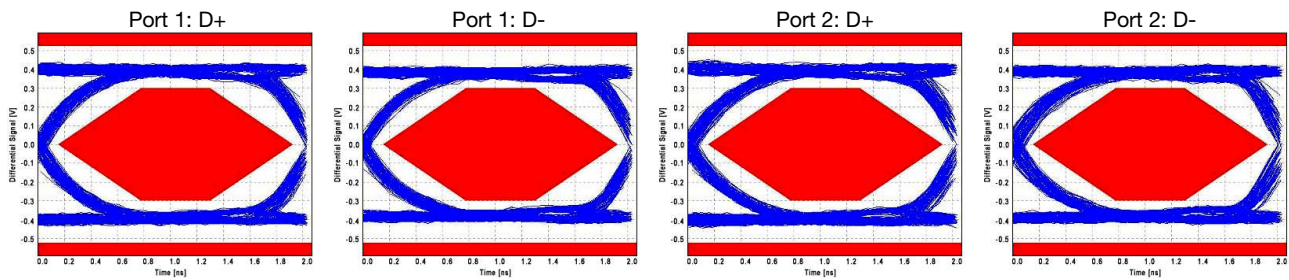

Eye pattern test with TVS diode WE-TV S p/n 824 015

The eye pattern test shows that the WE-TV S do not disturb the USB 2.0 signal. You would get the same result with our other here listed TVS diodes and with the ESD suppressors as well.

The following table shows the cutting edge ultra low capacitance technology of Würth Elektronik. This new technology enables a channel to channel capacitance which is almost invisible at normal operating conditions.

Order Code	Package	I/O	V _{RWM}	C _{IN}	C _X
824 015	SOT23-6L	4	5	2 pF	0.1 pF
Competitor S	SOT23-6L	4	5	3 pF	1.5 pF
824 001	SOT23-6L	4	5	1 pF	0.1 pF
Competitor P	SOT23-6L	4	5	3 pF	1.5 pF
I/O	Number of I/O lines the TVS-Diode can protect				
V _{RWM}	Max. reverse working voltage				
C _{IN}	Input capacitance at I/O pin via. GND (V _{IN} = 2,5V, VDD=5V)				
C _X	Input capacitance between I/O pins (V _{IN} = 2,5V, VDD=5V)				

Application Note



The Protection of USB 2.0 Applications

Testing the Protection Level of ESD Protection Devices

The easiest way to measure the protection level is to apply an ESD pulse to your electronic circuit with the ESD protection device and measure the peak voltage of this ESD pulse before and after the protection device. But this way carries out different problems.

Due to high frequency and wide range of ESD pulse (few MHz to some GHz) high frequency refractions will occur during the measurement. The absolute peak voltage and the spike voltages during the refractions are an indicator for better and worse protection, but you cannot indicate the definitive clamping voltage. And by the way, this is not a reliable and repeatable measurement!

Engineers being familiar with semiconductor products do know the TLP measuring method. The TLP (transmission line pulsing) method is an accurate measurement system which allows - due to all measurements are done in a 50Ω -System - repeatable and very accurate measurements.

A defined current impulse (left) is charged into the protection component and the resulting voltage across it is measured (middle). This procedure is repeated with increasing TLP currents. As a result you get the TLP curve (right).

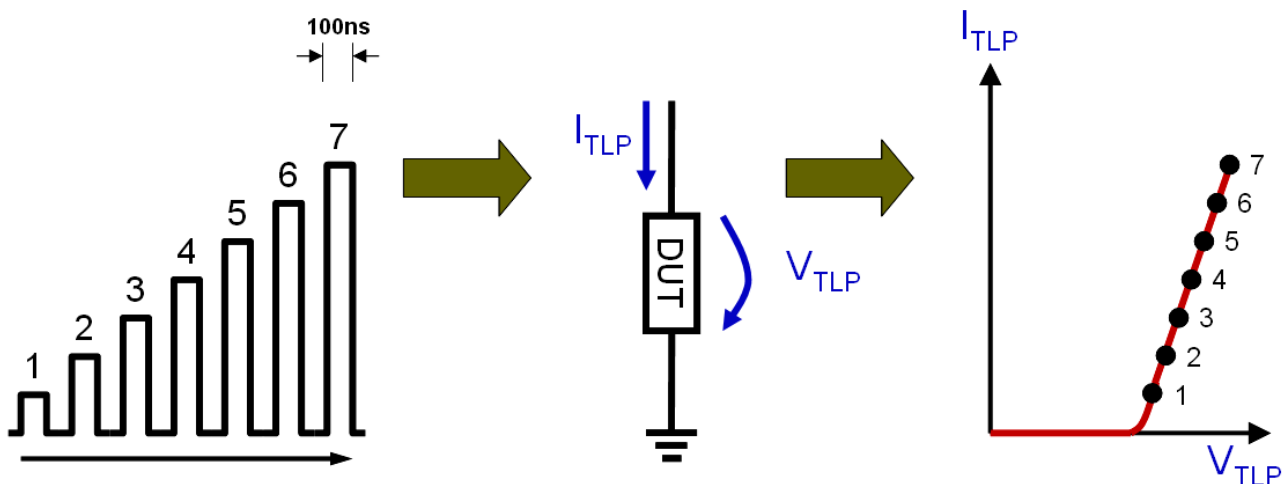

TLP measurement system with corresponding TLP curve

This measurement can be done for VDD and I/O pins. The lower the voltage you measure, the better is the protection device and therewith the reliability of your electronic circuit.

Thanks to the built in snap-back technology, Würth Elektronik TVS diodes have the lowest ESD clamping voltage on the market. Compared to competitors' products, the WE-TVS do outperform them clearly! This you can see with a short view at the TLP curves.

Application Note



The Protection of USB 2.0 Applications

Order Code	Package	I/O	V _{RWM}	V _{Cl,IO}	V _{Cl,VDD}	V _{ESD}	C _{IN}	I _{PP}
824 015	SOT23-6L	4	5	12	7,5	12 kV	2 pF	12 A
Competitor S	SOT23-6L	4	5	22	15,5	15 kV	3 pF	12 A
824 001	SOT23-6L	4	5	14	9	8 kV	1 pF	5 A
Competitor P	SOT23-6L	4	5	28	19	8 kV	3 pF	6 A

I/O	Number of I/O lines the TVS-Diode can protect
V _{RWM}	Max. reverse working voltage
V _{Cl,IO}	ESD clamping voltage at I/O pin (IEC 61000-4-2, contact mode at 6kV)
V _{Cl,VDD}	ESD clamping voltage at VDD pin (IEC 61000-4-2, contact mode at 6kV)
V _{ESD}	Max. withstanding ESD pulse (IEC 61000-4-2, contact mode)
C _{IN}	Input capacitance at I/O pin via. GND (V _{IN} = 2,5V, VDD=5V)
I _{PP}	Max. Withstanding surge current (8/20μs)

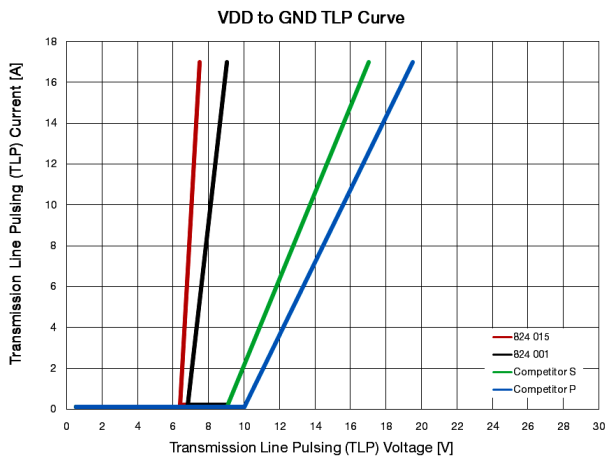

TLP Curve of different parts for VDD

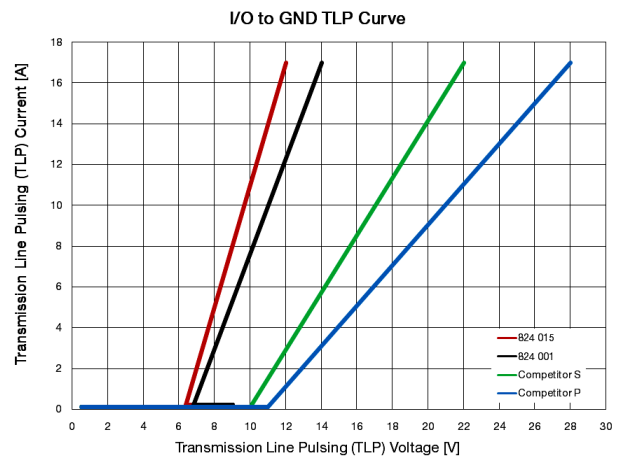

TLP Curve of different parts for I/O lines

Recommended Layout for Single USB Port

The two differential signal lines (D+ and D-) are routed from connector to TVS-Diode (p/n 824 011) and via a common mode choke (p/n 744 232 090) to the USB controller as shown on the left picture below. This results in an awesome ESD protection and EMI suppression of both data lines.

VBUS is routed like the signal line, but instead of the common mode choke a chip bead ferrite (p/n 742 792 641) is used. After the chip bead you may add a capacitor and a second chip bead as well to get the highest possible EMI suppression effect.

For very sensible IC's and / or high reliable applications you can get an optimized ESD suppression effect if you double contact a four-fold TVS array (p/n 824 015) like shown on right picture.

Application Note

The Protection of USB 2.0 Applications

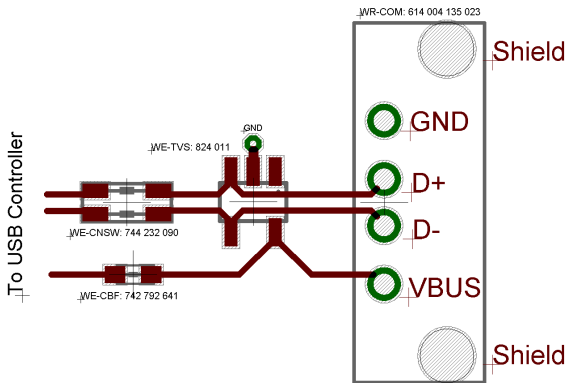

Protection of single USB port

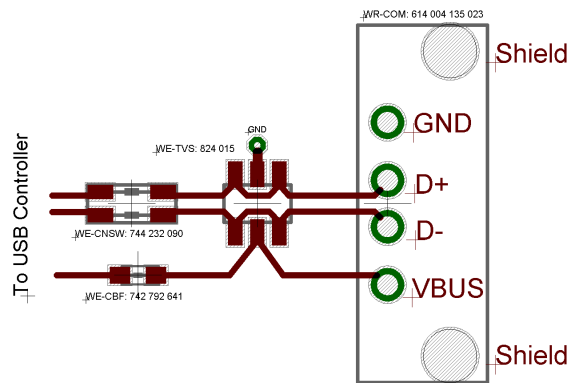

Double protection of single USB port

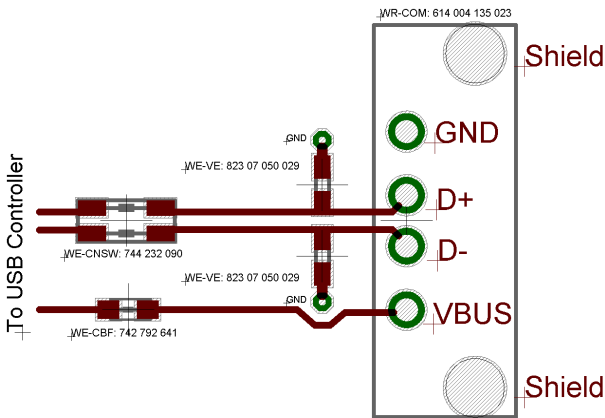

Protection of single USB port

Designers preferring single channel components can also use the ESD Suppressors WE-VE. The connection has to be carried out from D+ / D- to GND. The other parts are connected in same way as above.

Recommended Layout for Double USB Port

According to single USB port protection the routing is very similar. Use here exactly the same parts as for single port protection and the protection level will also be the same.

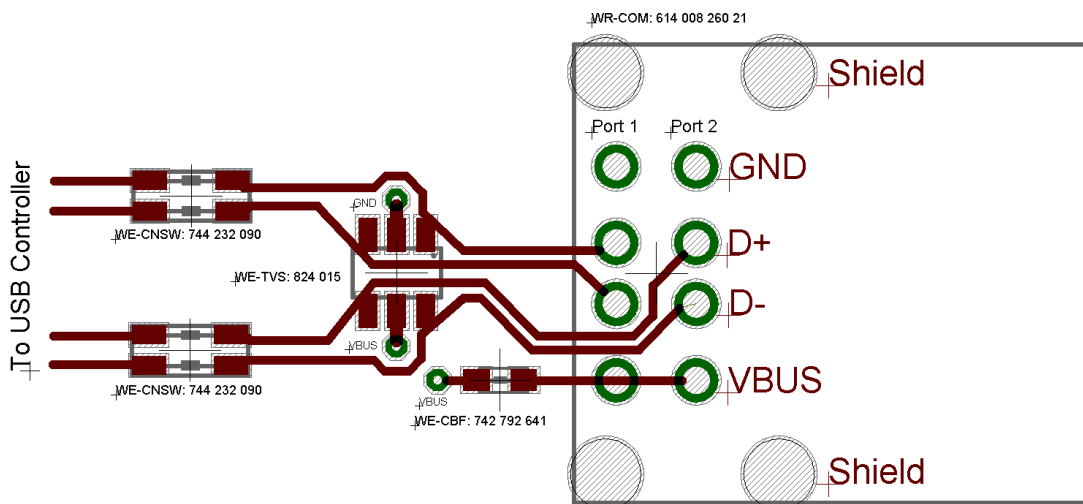

Protection of double USB port

Application Note



The Protection of USB 2.0 Applications

Bill of Material:

In this application note the following parts are used

TVS-Diodes WE-TVS:

824 011: Protection of 2 I&O lines and VDD line: Size SOT23-5L | 2pF $C_{I/O}$ | 5V V_{RWM} | 5A I_{PP}

824 015: Protection of 4 I&O lines and VDD line: Size SOT23-6L | 2pF $C_{I/O}$ | 5V V_{RWM} | 5A I_{PP}

ESD Suppressors WE-VE:

823 07 050 029: Size 0402 | 0.2pF C_{typ} | 5V V_{RWM} | 17V V_{CL}

823 06 050 029: Size 0603 | 0.2pF C_{typ} | 5V V_{RWM} | 30V V_{CL}

Common Mode Chokes WE-CNSW:

744 232 090: Size 1206 | 370mA I_{DC} | 300 m Ω R_{DC} | 90 Ω Impedance

Chip Bead Ferrites WE-CBF:

742 792 641: Size 0603 | 2 000mA I_{DC} | 150 m Ω R_{DC} | 300 Ω Impedance

USB-Connectors WR-COM:

614 008 260 21: USB Typ A Connector | THT | Dual stacked

614 004 135 023: USB Typ A Connector | THT | Vertical

Application Note

The Protection of USB 2.0 Applications



Interface Design Kit

For an easy design of interfaces Würth Elektronik has launched a special Interface Design Kit. This design kit includes a design guide for USB 1.0 to USB 2.0, CAN, Ethernet, VGA, DVI, RS232 and RS485 interfaces and all the components used. These are ESD Suppressors, SMD Common Mode Chokes, Chip Bead Ferrites, LAN Transformers and the corresponding Connectors.

In total are 35 different passive components with 235 parts and 4 evaluations boards in.

Interface Design Kit for USB, CAN, Ethernet, VGA, DVI, RS232, RS485
Order Code 744 999
Version 1.0

Part No.	Part Description	Part No.	Part Description	Part No.	Part Description	Part No.	Part Description
744 100 100	ESD Protection Mode Connector	744 200 100	ESD Protection Mode Connector	744 300 100	ESD Protection Mode Connector	744 400 100	ESD Protection Mode Connector
744 100 200	ESD Protection Mode Connector	744 200 200	ESD Protection Mode Connector	744 300 200	ESD Protection Mode Connector	744 400 200	ESD Protection Mode Connector
744 100 300	ESD Protection Mode Connector	744 200 300	ESD Protection Mode Connector	744 300 300	ESD Protection Mode Connector	744 400 300	ESD Protection Mode Connector
744 100 400	ESD Protection Mode Connector	744 200 400	ESD Protection Mode Connector	744 300 400	ESD Protection Mode Connector	744 400 400	ESD Protection Mode Connector
744 100 500	ESD Protection Mode Connector	744 200 500	ESD Protection Mode Connector	744 300 500	ESD Protection Mode Connector	744 400 500	ESD Protection Mode Connector
744 100 600	ESD Protection Mode Connector	744 200 600	ESD Protection Mode Connector	744 300 600	ESD Protection Mode Connector	744 400 600	ESD Protection Mode Connector
744 100 700	ESD Protection Mode Connector	744 200 700	ESD Protection Mode Connector	744 300 700	ESD Protection Mode Connector	744 400 700	ESD Protection Mode Connector
744 100 800	ESD Protection Mode Connector	744 200 800	ESD Protection Mode Connector	744 300 800	ESD Protection Mode Connector	744 400 800	ESD Protection Mode Connector
744 100 900	ESD Protection Mode Connector	744 200 900	ESD Protection Mode Connector	744 300 900	ESD Protection Mode Connector	744 400 900	ESD Protection Mode Connector
744 100 1000	ESD Protection Mode Connector	744 200 1000	ESD Protection Mode Connector	744 300 1000	ESD Protection Mode Connector	744 400 1000	ESD Protection Mode Connector

The colour scheme makes it easy to locate the suitable parts for your application. Just follow the specific application colour and arrange your needed parts.

CAN-Interface

RS 232 / 485 Interface

VGA

USB 2.0

Legend: Power Line (Red), Data Line (Blue), Electrochemical (Green)

For each application you find a simple block schematic where you see how to place the different components to get the best result. Try it - it's worth each penny!!